

# The Mercedes-Benz EQB



EQB







Innovative and functional on the inside.



Perfect for you: the EQB with MBUX.

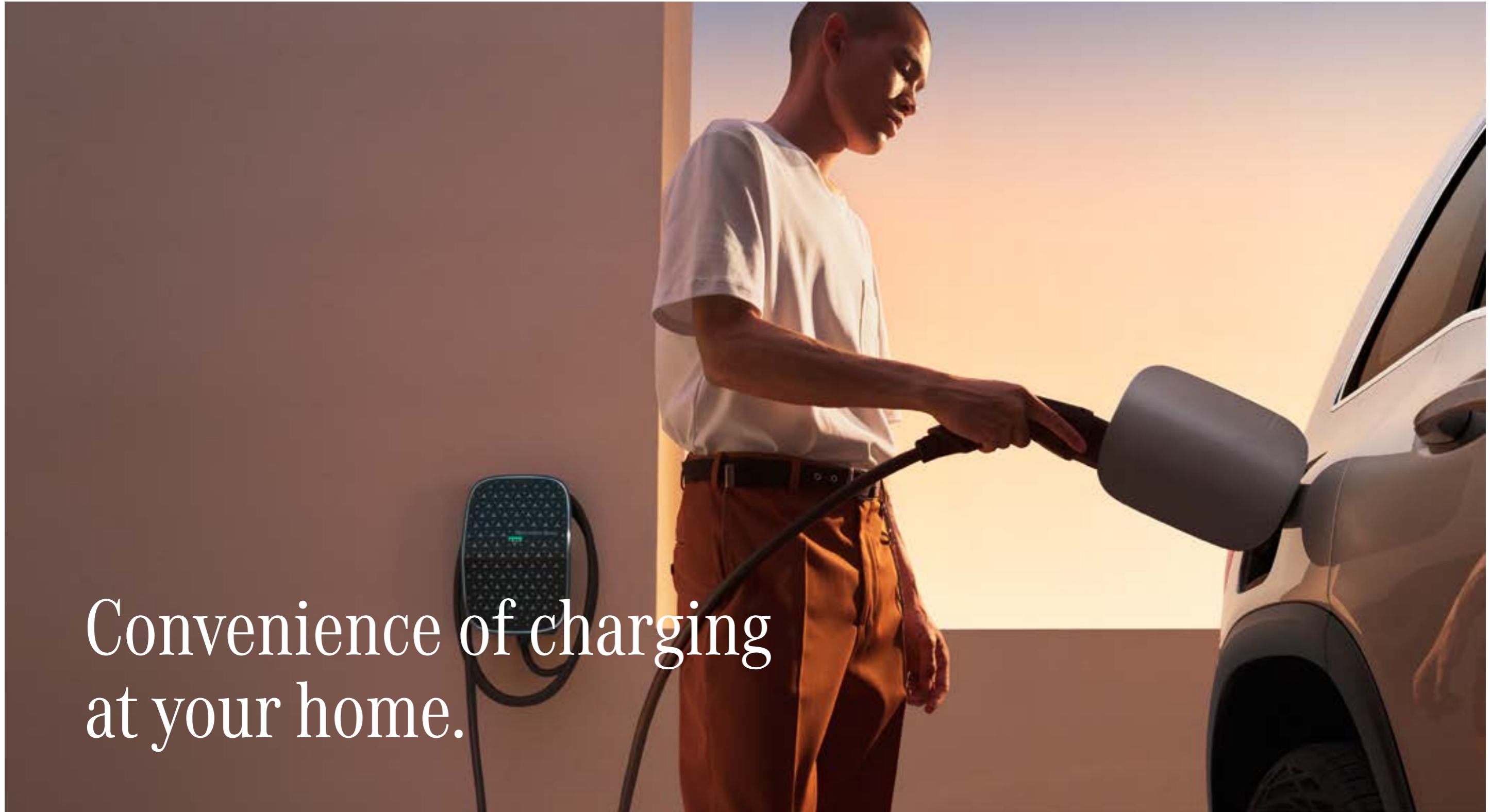

Convenience of charging  
at your home.

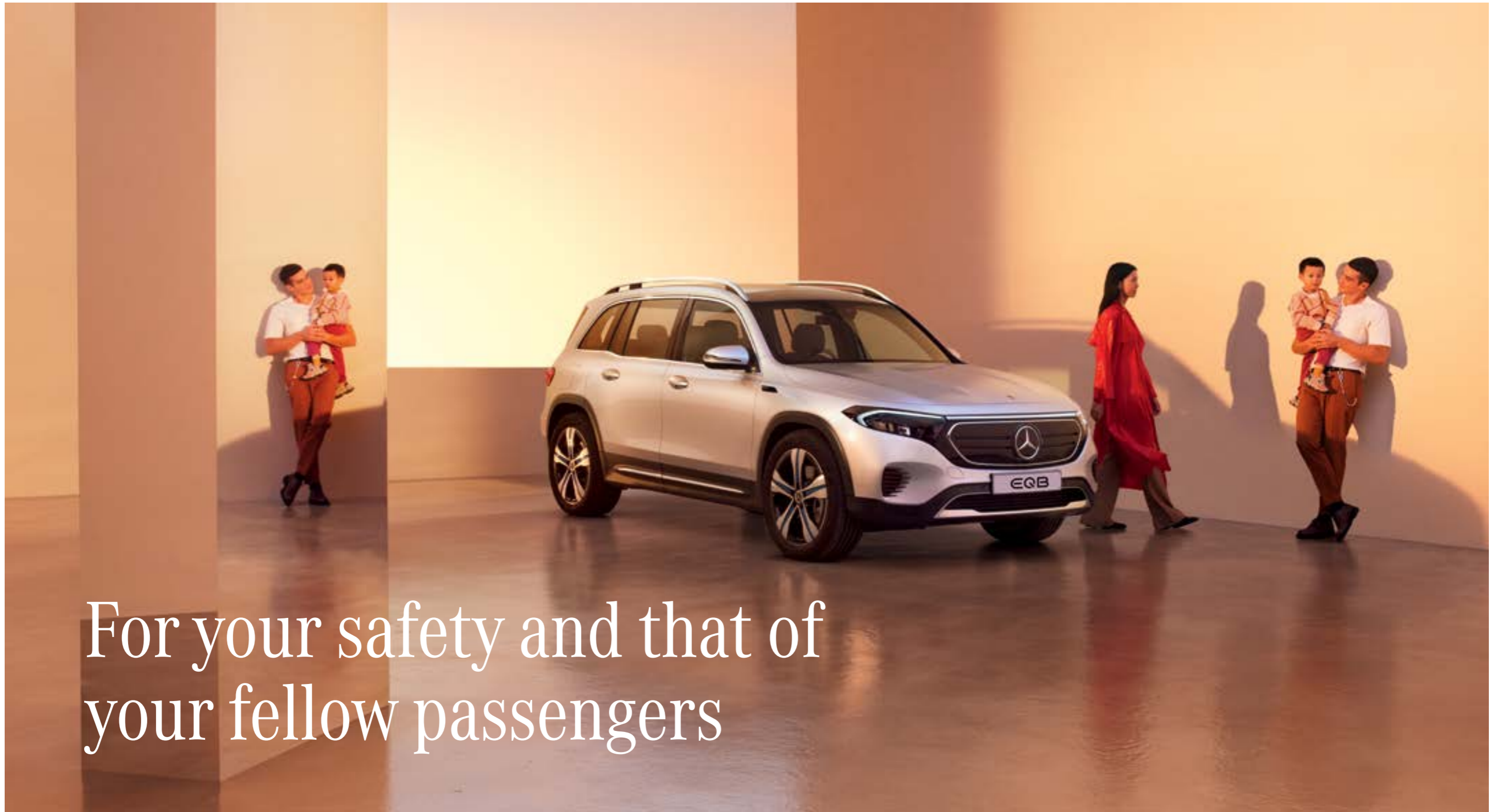

For your safety and that of  
your fellow passengers



# Sustainability

\*Please read the disclaimer

## Sustainable Production

### Mercedes-Benz Kecskemet plant

All of our Mercedes-Benz cars factories around the world plan to be CO<sub>2</sub> neutral. The EQB is built at the Mercedes-Benz Kecskemet plant in Hungary.



## Sustainable Materials

### Raw materials from certified mining

Mercedes-Benz looks at the entire value chain, from development and the supplier network to its own production. Responsibly mined and processed raw materials provide the foundation for a sustainable Mercedes-Benz electric vehicle fleet.

## Sustainable Mobility

### Pure Electric with pure emotions

Locally emission-free driving pleasure, virtually silent with full access to inner city zones.







# E-Motor & Battery

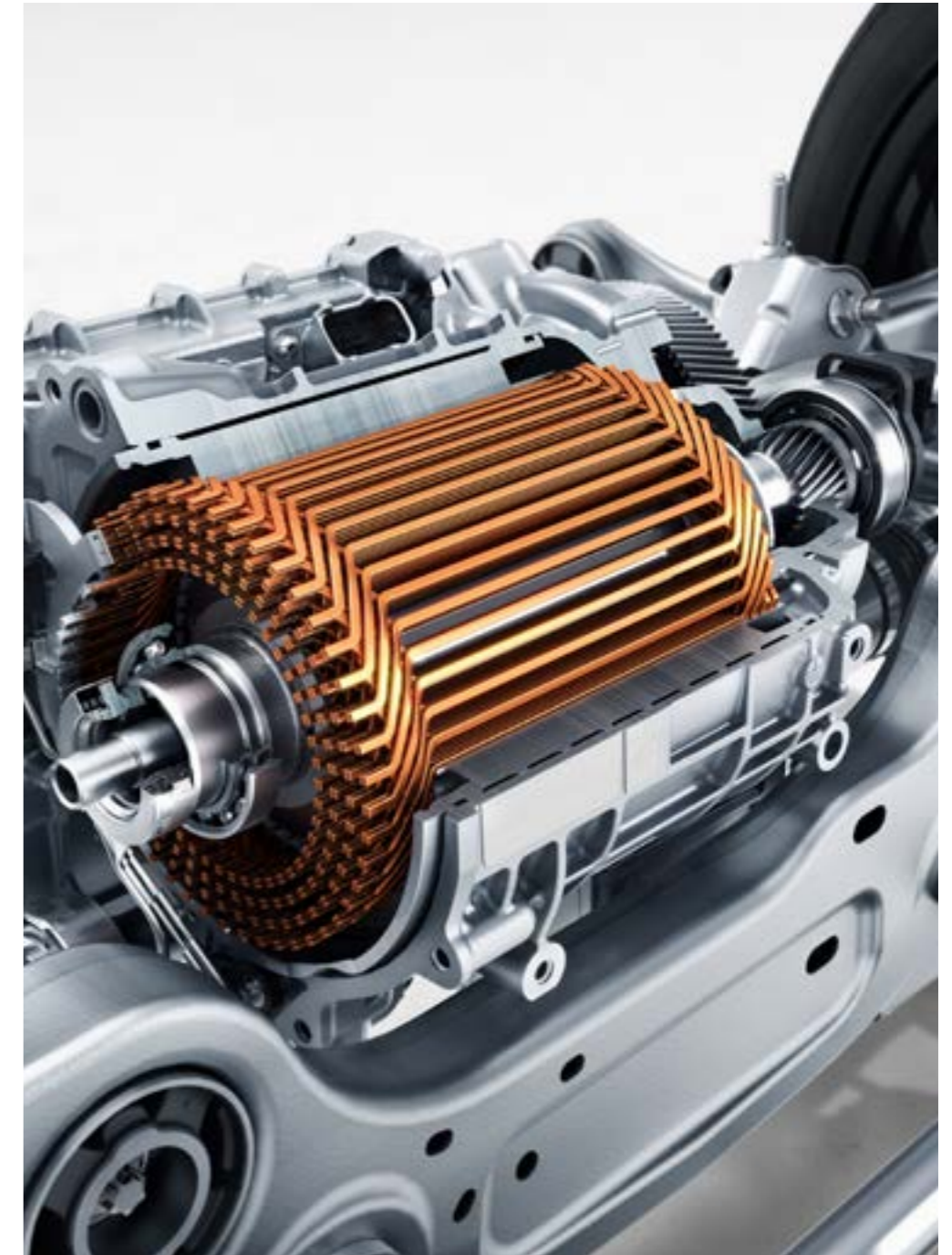

Dynamic acceleration and efficient cruising with the two electric machines of the electric drive system you can achieve both. The 4MATIC with torque shift distributes the torque as required and steplessly to the front and rear axle depending on the driving situation and road conditions. When you are not demanding any drive power from the electric machines, they can convert kinetic energy into electrical energy - for example when braking and use it to charge the high-voltage battery.



# Charging and Range



## Complimentary Wallbox Charger

Convenience is a true luxury! Now fully charge the EQB while relaxing on the sofa with the Wallbox. With a charging capacity of 11 kW you can charge the EQB from 10% to 100% within 6.25 hours. This is 3 times quicker than at a conventional household socket. After purchase, the Wallbox would be installed by our installation partner at your preferred location at home. With Mercedes-Benz EQB, you also get a complimentary fast charging at all our Franchisee Partners for one year.

## Alternate Current Charging System

### AC Charging System

Wallbox - 11 kW

10 - 100% in 6.25 hours

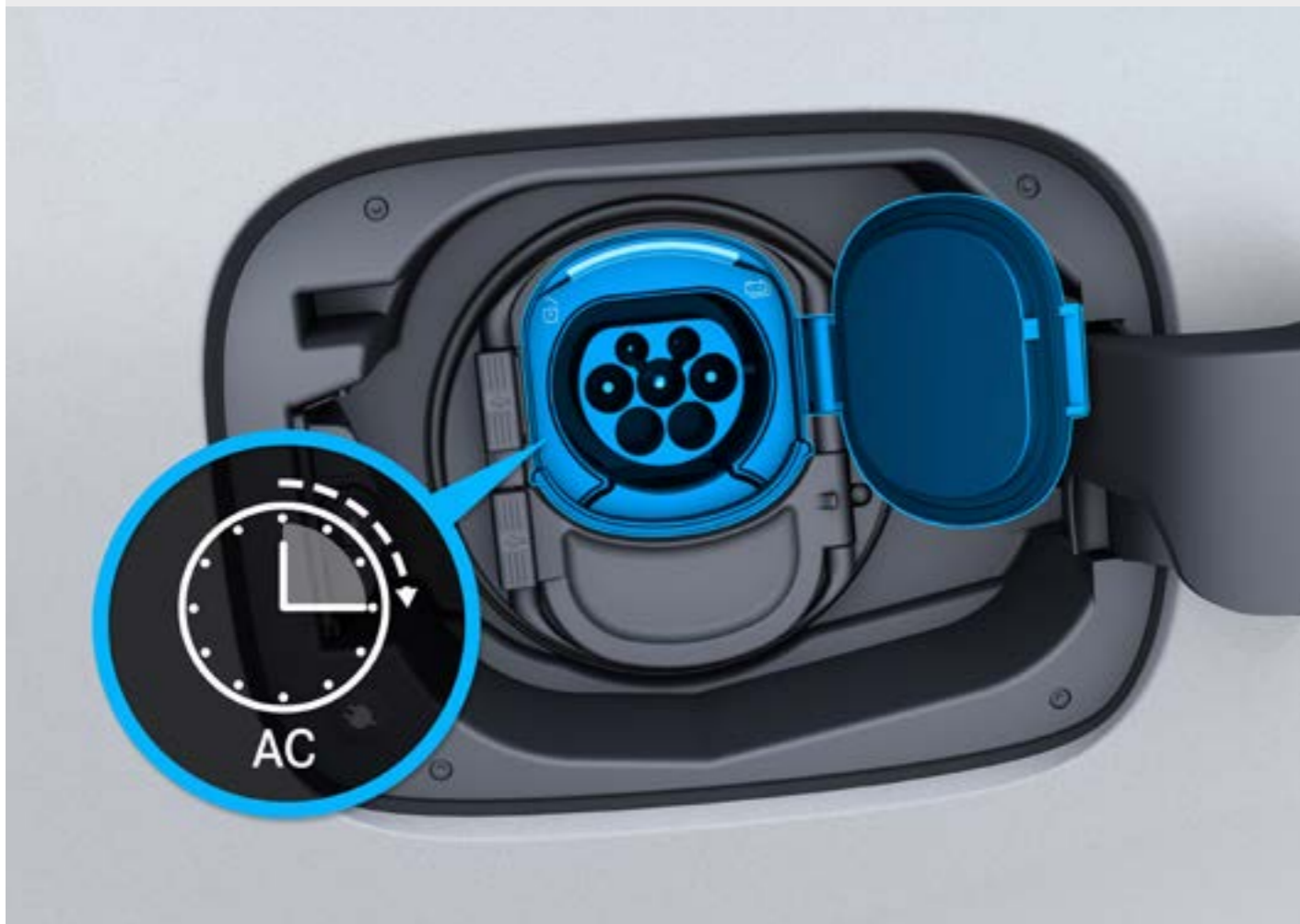

## Direct Current Charging System

### DC Charging System

Fast Charging - 100 kW

10 - 80% in 32 minutes





# Design

\*Please read the disclaimer



## Exterior

Full-width LED lighting elements accent

Mercedes-EQ signature Black Panel front end

45.7 cm (18-inch) 5-twin-spoke light-alloy wheels, aerodynamically optimised, painted in black with a high-shine finish.

Electric Art Exterior

Panoramic sliding sunroof

KEYLESS GO Comfort package

LED High Performance headlamps

EASY-PACK tailgate

Illuminated Door sills with EQB lettering

Parking package with reversing camera

Adaptive Highbeam Assist



## Interior

Ambient lighting - 64-colours

Velour floor mats

The Seat Comfort Package with its many adjustment options lets you find your ideal sitting position. It extends the supporting surface for the thighs by up to six centimeters.

Roof liner in black fabric

Roof liner in crystal grey fabric (optional)

3rd row of seats for 2 people can be quickly folded up or down at any time.

Driver's seat is electrically adjustable up to 3 different seat positions with memory function.

Multifunction sports steering wheel in nappa leather

DYNAMIC SELECT

Touchpad

Stowage compartment in centre console with retractable cover

Double cup holder

Spiral-look trim elements, backlit

Advanced Sound System

Load compartment package

Vehicle key in rose gold







# Luxury



With Advanced Plus package you tangibly gain comfort, and additionally you also receive the KEYLESS-GO Convenience Package. Your wellbeing during the journey is also fostered by the two-zone automatic climate control THERMOTRONIC and the powerful sound system. Meanwhile you can recharge your smartphone wirelessly.

Wireless charging system for mobile devices in the front

4-way lumbar support for an ergonomic seating position and relaxed back muscles

HANDS FREE ACCESS for rear tailgate

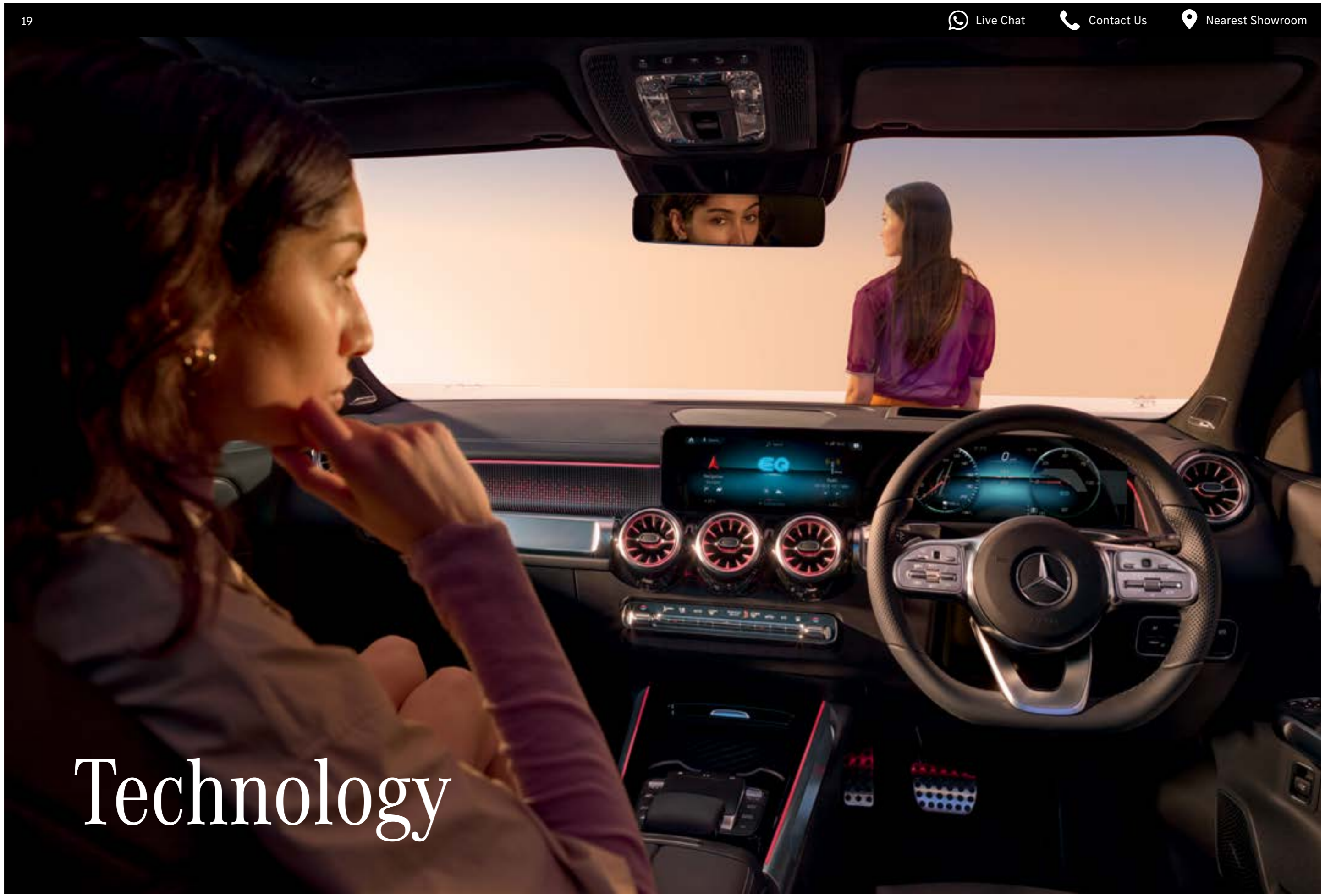

# Technology

The world of Mercedes me offers numerous services for your electric driving convenience. The navigation and Active Range Monitoring give you certainty with respect to range – including necessary charging stops.

With Preinstallation for Navigation Services your vehicle answers your questions about your journey like you can find out about the number of currently available parking spaces or the current weather. Hence making your trip even easier.

Preinstallation for Live Traffic Information helps you receive traffic information in real time which is more precise and up-to-date than conventional systems and optimises dynamic route guidance.

This combination of Mercedes me connect services and hard-disc navigation allows you always to find the best route while ensuring that you are ideally informed at all times.





Enjoy the beauty and intelligence of a digitised multimedia system with MBUX multimedia system.

Extended MBUX functions like personal profiles, predictive functions completely redefine the term digital networking.

Experience the entire range of digital display possibilities with all-digital instrument display.

Smartphone integration links the mobile phone with the media system via Apple® CarPlay® or Android Auto®. This gives you convenient access to the most important apps on your smartphone.

Save time, thanks to fast Hard Disk Navigation with flexible options for entries via touch control or voice input.





# Safety

\*Please read the disclaimer

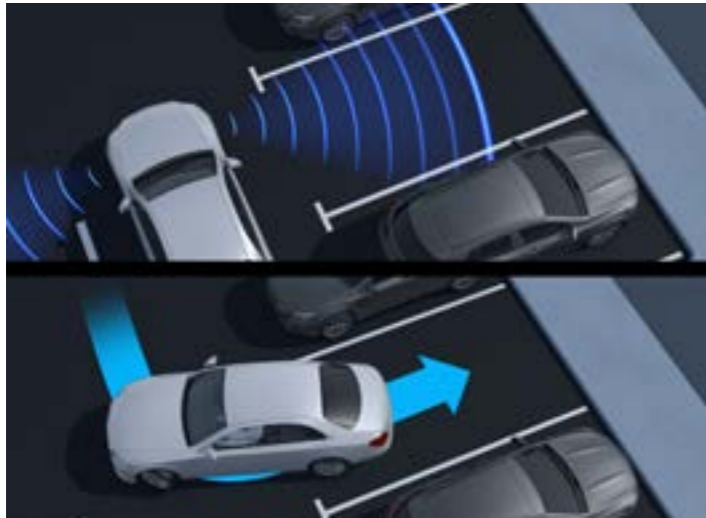

Active Parking Assist with PARKTRONIC makes parking smooth and effortless the system can detect suitable available parking spaces and assists with driving forwards and backwards into end-on parking spaces by taking over the steering for you.

Blind Spot Assist is able to give you a visual and audible warning of impending side collisions with other road users in the blind spot.



Active Brake Assist can help you to avoid rear-end collisions with stationary vehicles or vehicles in front.



With a continuous line, or if the lane behind a broken line has been identified as occupied, the Active Lane Keeping Assist system can intervene further with braking on one side of the vehicle.

Tyre pressure monitor system monitors the tyre pressure for you and provides you with a warning in the event of a drop in pressure.



The acoustic presence indicator generates specific Mercedes-Benz sounds outside of the vehicle up to a speed of 20 km/h, So that your electric vehicle also does not pose a danger to pedestrians and cyclists when driving virtually silently.

The knee airbag protects your legs from contact with the steering column or the dashboard in a severe frontal crash. This can prevent or lessen the severity of injuries.



## Paintwork



**Digital White**



**Cosmos Black**



**Iridium Silver**



**Rose Gold**



**Mountain Grey**



## Upholstery



**ARTICO man-made leather / Cupertino fabric, two-tone rosé gold / titanium grey pearl**

## Trim



**Spiral look trim**

## Interior Features

EQB 350 4MATIC

Ambient lighting - 64-colours	●
Velour floor mats	●
The Seat Comfort Package with its many adjustment options lets you find your ideal sitting position. It extends the supporting surface for the thighs up to six centimeters.	●
Roof liner in black fabric	●
Roof liner in crystal grey fabric (optional)	●
3rd row of seats for 2 people can be quickly folded up or down at any time.	●
Driver's seat is electrically adjustable up to 3 different seat positions with memory function	●
Multifunction sports steering wheel in nappa leather	●
DYNAMIC SELECT	●
Touchpad	●
Stowage compartment in centre console with retractable cover	●
Double cup holder	●
Spiral-look trim elements, backlit	●
Advanced Sound System	●
Load compartment package	●
Vehicle key in rose gold	●

● Standard

## Exterior Features

EQB 350 4MATIC

Full-width LED lighting elements accent	●
Mercedes-EQ signature Black Panel front end	●
45.7 cm (18-inch) 5-twin-spoke light-alloy wheels, aerodynamically optimised, painted in black with a high-sheen finish	●
Electric Art Exterior	●
Panoramic sliding sunroof	●
KEYLESS GO Comfort package	●
LED High Performance headlamps	●
EASY-PACK tailgate	●
Illuminated Door sills with EQB lettering	●
Parking package with reversing camera	●
Adaptive Highbeam Assist	●
Vehicle key in black with rose gold	●

● Standard

## Technology Features

EQB 350 4MATIC

Alternating current charging system (AC charging) up to 11 kW	●
Direct current charging system (DC charging) up to 100 kW	●
Charging time	●
Fast Charging (100 kW DC) 10-80% - 32 mins	●
Wallbox (11 kW AC) 10-100% - 6.25 hrs	●
MBUX multimedia system.	●
Extended MBUX.	●
Digital Display	●
Smartphone integration	●
Hard Disk Navigation	●
Active Range Monitoring	●
Preinstallation for Navigation Service	●
THERMOTRONIC automatic climate control	●
Preinstallation for Live Traffic Information	●
Load compartment package	●
Vehicle key in rose gold	●

● Standard

## Safety Features

EQB 350 4MATIC

Active Parking Assist with PARKTRONIC	●
Active Brake Assist	●
Acoustic Presence Indicator	●
Blind Spot Assist	●
Active Lane Keeping Assist	●
Tyre Pressure Monitor	●
Knee Airbag	●

● Standard

## Technical Data

### EQB 350 4MATIC

<b>Battery type</b>	Lithium-ion High power density
<b>Electric motors</b>	Front Axle: Asynchronous motor (ASM) Rear Axle: Permanently excited synchronous motor (PSM)
<b>Battery capacity</b>	66.5 kWh
<b>Power hp</b>	215 kW (292 hp)
<b>Torque</b>	520 Nm
<b>On-board charger</b>	11 AC; 100 DC kW
<b>Transmission</b>	Single-speed transmission
<b>Acceleration</b>	6.2 sec
<b>Top speed</b>	160 km/h
<b>Fast Charging</b>	32 min (100 kW DC) 10-80%
<b>Wallbox</b>	6.25 hrs (11 kW AC) 10-100%
<b>Range power consumption combined</b>	18.1 - 19.4 kWh/100 km
<b>Electric range - WLTP</b>	388.0 - 423.0 km

# Dimensions

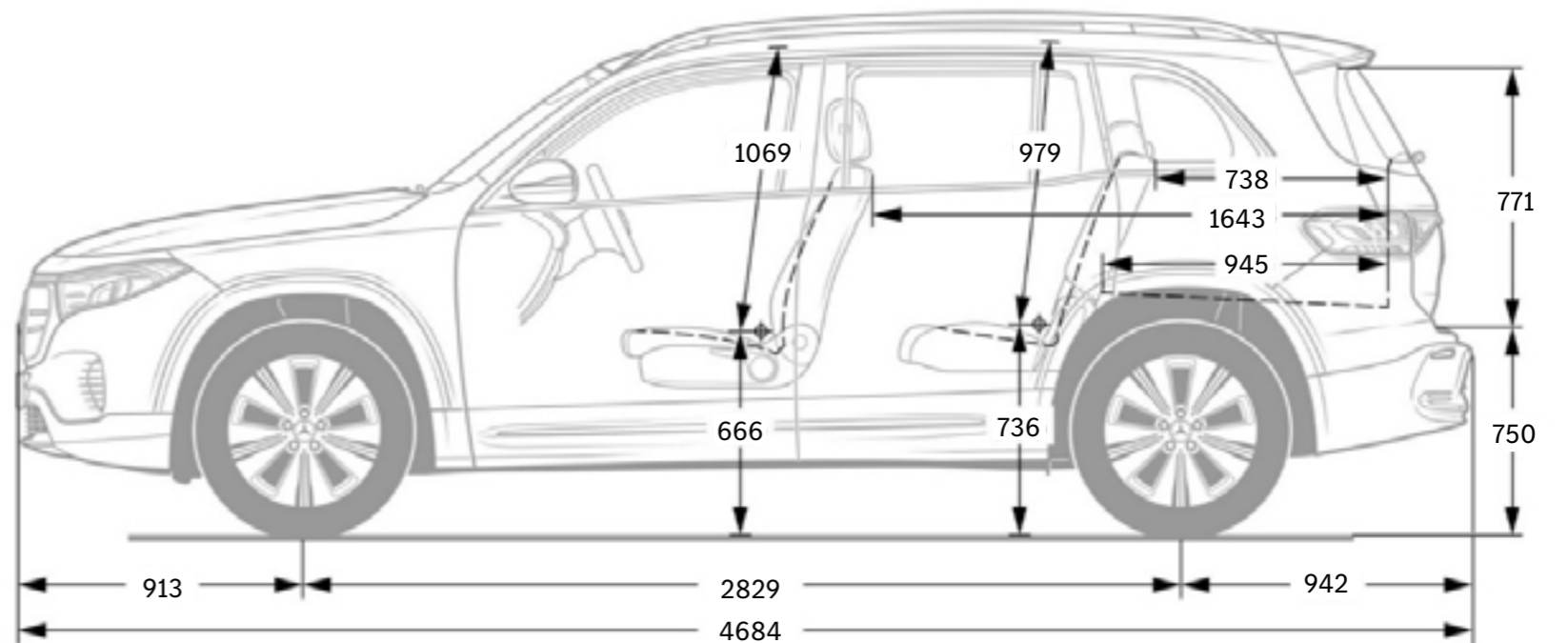
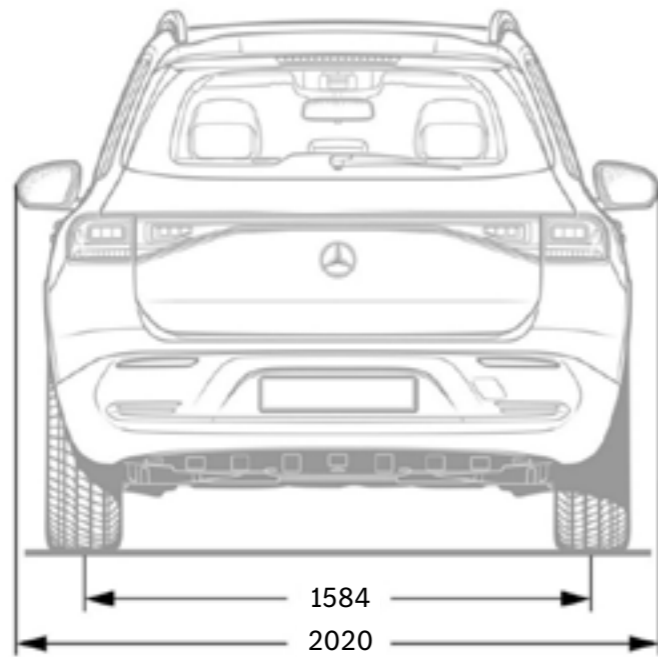
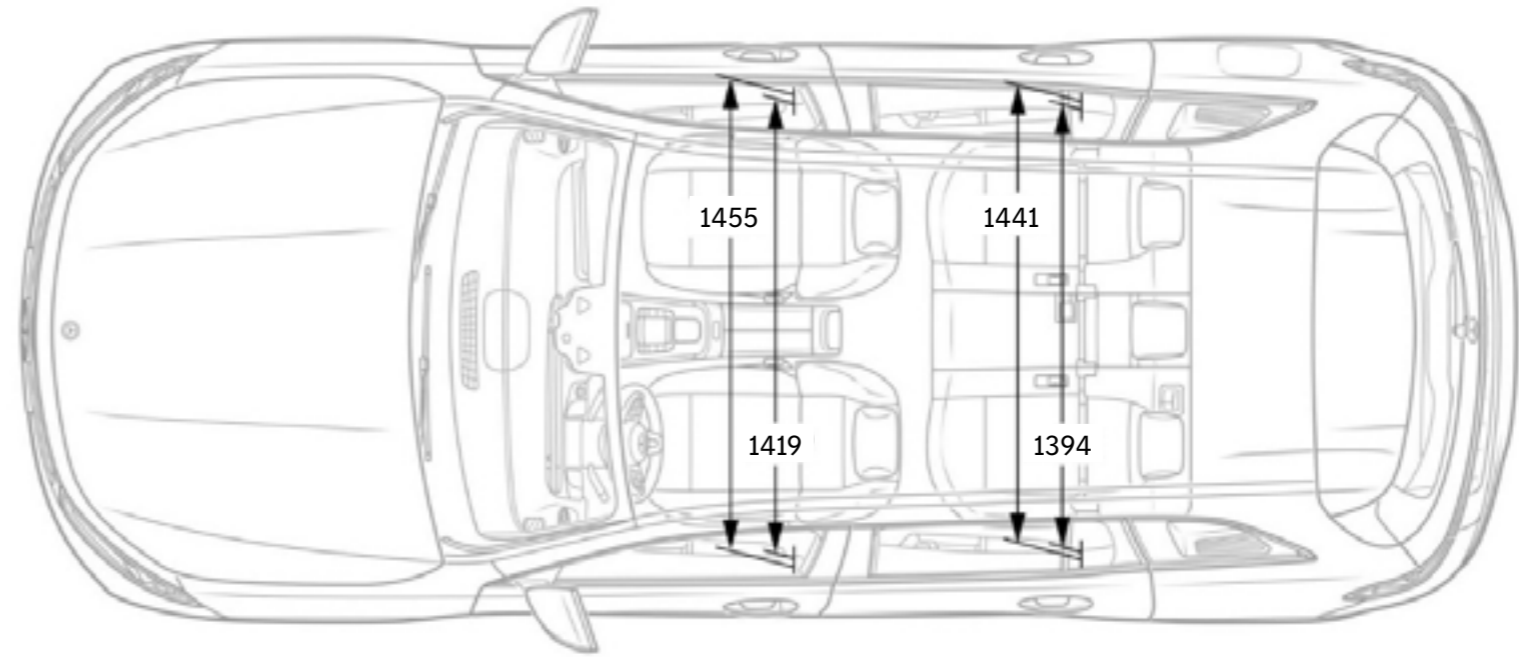
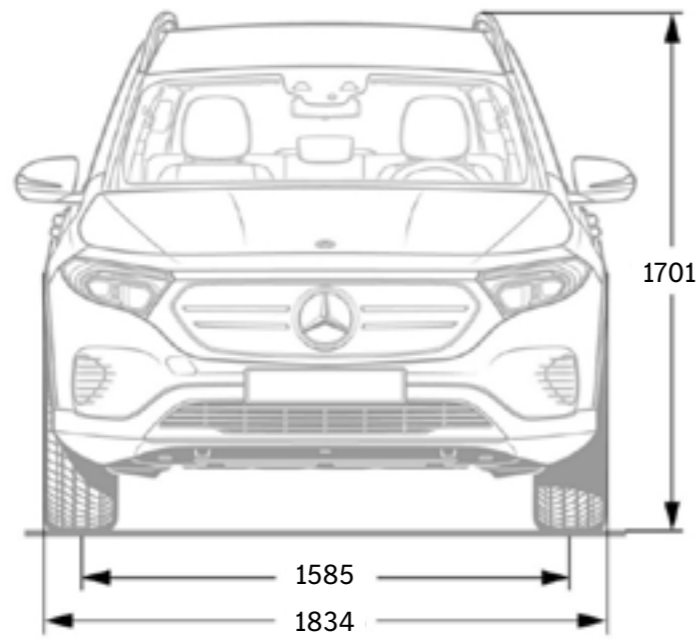

\*Please read the disclaimer

\*All dimensions are in mm



**My Mercedes. My Service**

## **Advance Assurance Program**

### **Extending your warranty coverage**

With Advance Assurance Program, experience complete peace of mind. While this Extended Warranty Program kicks in the moment your standard 3 years warranty comes to an end, it can be extended further up to 6 years at a nominal price. Also, it comes with a bouquet of privileges for a worry-free time with your Star.

## **STAR EASE**

### **Delivering the best-in-class value**

Servicing your Star does not get any better than this. With the STAR Ease Maintenance Packages, pay a defined cost of maintenance based on the model, contract period and mileage and say goodbye to spending on service every time. Plus, enjoy exclusive features like priority handling, shorter waiting time and quicker processes.

## My Mercedes. My Service

### MOBILO

#### Providing you 24x7 mobility support

Your vehicle comes with Mobilo which provides round-the-clock on-road assistance service. Mobilo comes as a standard for 3 years and can be extended further up to 8 years at a nominal cost. This service offers privileges like vehicle towing facility, replacement vehicle, hotel accommodation, just to name a few.

### Digital Service Drive

#### Ensuring convenience and transparency of service.

Servicing your Star is the last thing you will ever have to worry about. We provide transparent, convenient and hassle-free service. Our customer-friendly service features work around your busy schedule so that you have one less thing to focus upon.





**My Mercedes. My Service**

## Mercedes-Benz Genuine Parts

### Now with 2 years\* of warranty

Mercedes-Benz Genuine Parts are crafted to the state-of-the-art standards of Mercedes-Benz, protecting your vehicle's performance while maintaining the style, comfort and safety, for the years to come. Also, they come with a warranty of up to 2 years, ensuring you a peaceful ownership experience with your Star.

## Premier Express\*

### Because we value your time as much as you do.

Life gets busy and so we have designed Premier Express, our vehicle care service to help you get in and out quickly. While the visit will be brief, the service offered by our technicians will be comprehensive and complete. All to ensure your Mercedes-Benz is running for miles to come.



## My Mercedes. My Service

### Mercedes-Benz Approved Tyres and Rims

#### Ensuring every ride is a safe and joyful one

Maximise the safety and comfort of your Star with Mercedes-Benz approved tyres and rims. While the Mercedes-Benz approved tyres are designed to optimally match your car's performance, the Mercedes-Benz approved rims are designed to lend an exceptional style to the exterior of your Star and are also engineered for optimal performance.



# EQ Charging Stations across Nationwide Franchise Partners.

## What's in it for you.

Biggest Ultra-Fast charging network in India.  
 Exclusive for Mercedes-Benz Electric Cars.  
 Complimentary service till the end of 2023.  
 24 x 7 facility available.

AC Charging System	DC Charging System	
Wallbox	Fast Charging	
100+ locations	34 locations	
11 kW	60 kW	180 kW
	21 locations	13 locations

Your Mercedes-Benz electric car comes with a complimentary Wallbox charger.





Mercedes-Benz India Private Limited: E-3, MIDC Chakan - Phase III, Chakan Industrial Area, Kuruli & Nighoje, Tal: Khed, Pune - 410 501 (India) Toll free No.: 0008000501888. e-mail: cs.ind@cac.mercedes-benz.com, website: www.mercedes-benz.co.in Please note: This brochure is intended for general information, description and illustration of the Product including optional functions and equipment and may not be specific to a Product since specification of a product may change from time to time. Optional features, functions and equipment etc. may not be present in the Standard or Variant Product or Special Edition Product. Further, Standard specifications of a product may also vary from time to time. Colours may differ from those shown in pictures in the brochure. Mercedes-Benz India reserves the right to make changes without prior notice, in design, colours, materials, components, equipment, specifications, features, functions, make and models etc. The information given in this brochure shall be regarded as accurate at the time of launch and may vary thereafter due to any developments or any other reason. Interested customers should reach out to the Authorised Franchise Partner for further information on the exact specifications, features of the product.

Images shown are for representation purposes only. Some of the vehicles in the Brochure are left hand drive wheel. However, Mercedes-Benz India only manufactures and sells vehicles as per the applicable motor vehicle regulations in India. All vehicles sold by Mercedes-Benz Authorized Franchise Partners shall be with right hand drive wheels only. All title, ownership rights and intellectual property rights in and relating to this brochure/magazine or publication material or any copies thereof including but not limited to copyright, logos, names, trademarks, service marks, design, text, images, links, concepts and themes are owned by Mercedes-Benz Group AG and/or its subsidiaries collectively or used under authorised license by the Mercedes-Benz Group AG. Any reproduction, transmission, publication, performance, broadcast, alteration, license, creation of derivative works or other use in whole or in part in any manner without the prior written consent of Mercedes-Benz India Pvt. Ltd is strictly prohibited. Please note that certain services are offered free of cost for a period of three (03) years and may be chargeable at the expiry of three (03) years from the date of activation of such services. If you wish to continue using those services, you may renew the same through Mercedes Me Store (as and when it is available). Please get in touch with your preferred Franchise Partner for more details. Mercedes-Benz cars: The EQB meets Bharat Stage VI equivalent emission norms.  
CIN - U34102PN1994PTC083160